



© 1995-2020 by Isidoro Martínez

Thermal convection in space

by [Isidoro Martínez](#)

(prepared during [coronavirus pandemic](#) confinement)

2020-April-1st

“There is not heat convection in space” may be the normal answer found.

- Convection requires a fluid flow, and the vacuum of space prevents it.
- In fact, many experiments in space are justified by the absence of convection (although there are a few aiming at the study of convection, like [Geoflow](#), to simulate the flow in the atmosphere and the oceans).
- A more refined analysis may restrict the former quoted sentence to say: “There is no natural convection in space” because there is no buoyancy in weightlessness.
- An opposite generalisation may be that ‘heat is taken from the source by conduction, heat is transported from source to sink by convection, and heat is evacuated at the sink by radiation’.

We adopt here a wide scope, to include forced thermal convection inside pressurised spacecraft and space suits, including rocket engines, sloshing in liquid tanks, planetary atmospheres and re-entry, stratospheric ships, capillary driven convection inside heat pipes, convection due to microacceleration by residual air drag (microgravity) and other perturbances (g-jitter), etc.

Let start by analysing what is ‘heat’ and what is ‘convection’.

Heat, Q , is not convected; it is thermal energy, E , that is convected (carried by a fluid). Heat is the flow of energy due to a temperature difference. [Heat transfer](#) may take place:

- By electromagnetic long-range interaction, i.e. by [radiation](#), either between opaque surfaces, or through semitransparent media. There is no general model, but a convenient one for an opaque convex body of surface area A , wall temperature T_w , and emissivity ε , seeing only a large enclosure at T_∞ , is:

$$\dot{Q} = A\varepsilon\sigma(T_w^4 - T_\infty^4)$$

- By atomic close-range interaction, i.e. by contact or within material systems. This is named [heat conduction](#) or heat diffusion, and the general model is based on thermal conductivity, k , and Fourier's law, which, by unit area is:

$$\vec{q} = -k\nabla T$$

However, a third mode of heat transfer is traditionally considered, [heat convection](#), which is the combination of heat conduction and fluid advection. When only an empirical approach is sought, heat convection is modelled as a boundary condition at a solid/fluid interface, using **Nusselt** non-dimensional parameters and Newton's cooling law, which is just the definition of the convective coefficient h :

$$\dot{q}_{\text{wall}} = (-k\nabla_n T)_{\text{solid}} = (-k\nabla_n T)_{\text{fluid}} \equiv h(T_{\text{wall}} - T_{\text{bulk.fluid}}) \rightarrow \frac{hL}{k} \equiv Nu(Re, Pr\dots)$$

When heat convection within a fluid is analysed, Fourier's law is used (not Newton's cooling law). Just to have a glance at it, the balance equations of fluid flow in an Eulerian frame of reference (fix) are here presented:

- Mass balance (continuity):
$$\frac{\partial \rho}{\partial t} + \nabla \cdot (\rho \vec{v}) = 0$$

- Momentum balance:
$$\frac{\partial (\rho \vec{v})}{\partial t} + \nabla \cdot (\rho \vec{v} \vec{v}) = \rho \vec{g} + \nabla \cdot \bar{\bar{\tau}}$$

- Energy balance:
$$\frac{\partial (\rho e)}{\partial t} + \nabla \cdot (\rho e \vec{v}) = \nabla \cdot (k \nabla T) + \nabla \cdot (\bar{\bar{\tau}} \cdot \vec{v})$$

where e here is specific energy (i.e. energy per unit mass, E/m , including internal energy and mechanical energy, as used in Thermodynamics, not as in Fluid Mechanics, where e is used for internal energy alone). The latter can be modified to be more directly compared with the traditional thermodynamic formulation without shaft work (which is a boundary condition in Fluid Mechanics):

$$\frac{\partial (\rho e)}{\partial t} = \nabla \cdot (k \nabla T) + \nabla \cdot (\bar{\bar{\tau}} \cdot \vec{v}) - \nabla \cdot \left(\rho \left(e + \frac{p}{\rho} \right) \vec{v} \right) \Leftrightarrow \frac{dE}{dt} = \dot{Q} + \dot{W}_{\text{dis}} + \sum^{\text{openings}} \dot{m}_e h_{t,e}$$

The importance of non-dimensional analysis:

- The number of variables is reduced (by the number of physical units involved), a great advantage when there are many variables.
- The parameters acquire general meaning, independent of the unit system used. The mass balance provides the Strouhal number for unsteady flows, $Sr=fL/v$; the momentum balance provides the Reynolds number, $Re=\rho vL/\mu$; and the energy balance adds the Prandtl number, $Pr=\mu c_p/k$. The Nusselt number, $Nu=hL/k$, is introduced as a solid/fluid interfacial parameter, and the empirical approach to heat convection is finding non-dimensional correlations $Nu=f(Re,Pr\dots)$ that allow the computation of h and finally the heat flow:

$$\dot{Q}_{\text{conv}} = hA(T_{\text{wall}} - T_{\text{fluid-bulk}})$$

- Their order of magnitude helps to concentrate on the most important ones.
- Results are independent of the scale, showing physical similarity., and allowing scale-down experimentation (e.g. on wind tunnels).

The importance of boundary-layer flows:

- In most practical cases, fluid flows is at high Reynolds' number, and the perturbation on flow variables (velocities, temperature, and species concentrations) due to boundary conditions are only important close near the bounds, although this is not truth at the rear of obstacles because the perturbation (momentum wake, thermal plume, and species trails) extends far away, neither it is true in supersonic flow because the Mach cones extend far away.

Normal fluids are poor heat conductors: in $W/(m \cdot K)$, $k_{\text{air}}=0.02$, $k_{\text{water}}=0.6$, vs. $k_{\text{alu}}=150$. Nanofluids are normal liquids with suspended solid nanoparticles, $d < 100$ nm, metallic or ceramic, treated to prevent agglomeration, which enhance conductivity by $>10\%$ with $<1\%$ in mass. But fluids convect 'heat'. Hence, ice, with $k_{\text{ice}}=2.3 W/(m \cdot K) > k_{\text{water}}$, is used as insulation in igloos (and spoils convective heat transfer, and require defrosting).

On top, phase change absorbs/releases lot of energy; $h_{\text{LV,water}}=2.5 \text{ MJ/kg} \leftrightarrow \Delta T_{\text{liq}}=600 \text{ K!}$
 Sublimation (ice-to-vapour, used in spacesuits). Ablation (with chemical change) \rightarrow TPS.

We deal here with liquid/vapour phase change, not solid phase change materials (PCM) used as heat buffers.

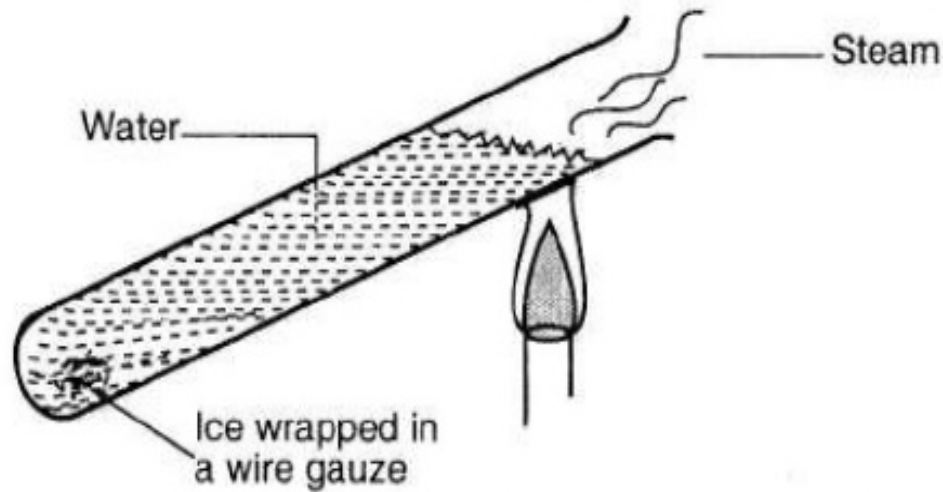

Fig. 1. Water may be boiling at the top while ice (weight-loaded) remains at the bottom.

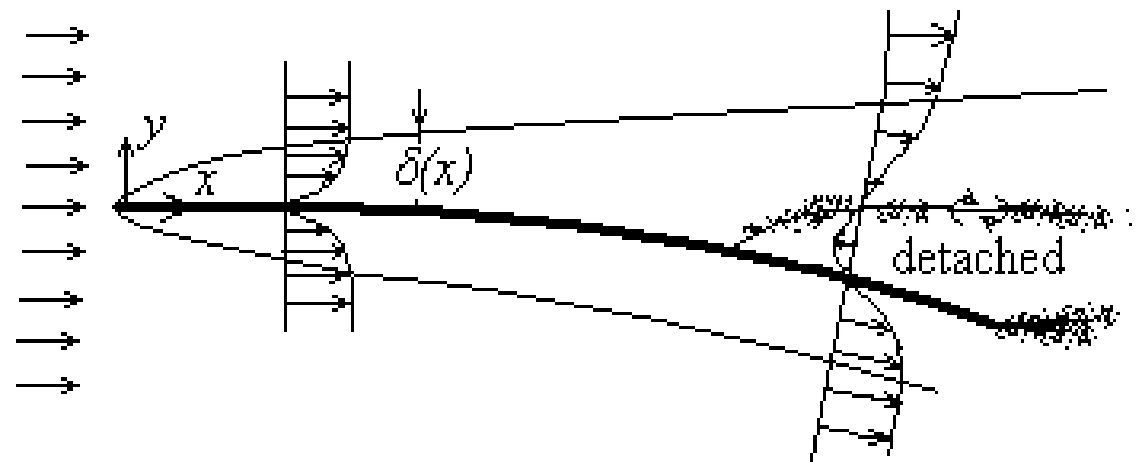

Fig. 2. Boundary layer flow over a curved thin plate with zero incidence, to show flow detachment.

Classification of heat convection processes

(free / forced, internal / external, laminar / turbulent, single flow / two-phase flow)

- Single-phase flow / Two-phase flow

Single phase fluids: air, water, water/propyleneglycol, silicone oil... (all used in the IIS).

- Natural convection; requires g (in μg astronauts need fans to survive) and $\Delta\rho$ (caused by temperature or composition gradients); e.g. Mars landers.
 - Laminar flow: $Ra = g\alpha\Delta TL^3 / (\nu\alpha) < 10^7$. $Nu = 0.54 \cdot Ra^{1/4}$. In air, $h \approx 10 \text{ W}/(\text{m}^2 \cdot \text{K})$.
 - Turbulent flow: ($Ra > 10^7$) $Nu = 0.15 \cdot Ra^{1/3}$. In air at 10 m/s, $h \approx 100 \text{ W}/(\text{m}^2 \cdot \text{K})$.
- Forced convection. Fans&Pumps. Flow through porous media (perfusion).
 - Laminar pipe flow: $Re < 2300$, $Nu_D \approx 4$. Flat plate: Chilton-Colburn analogy for $Pr > 0.6$: $Nu = 0.66 \cdot Re^{1/2} Pr^{1/3}$.
 - Turbulent pipe flow: $Re > 4000$. Dittus-Boelter correlation: $Nu_D = 0.023 \cdot Re^{0.8} Pr^n$, with $n = 0.4$ if T_{fluid} grows, $n = 0.3$ if T_{fluid} cools, for $0.6 < Pr < 200$. Same for turbulent plate (but $Re_{\text{turb}} > 5 \cdot 10^5$); e.g. the walls of the launch vehicle heat up to 450 K (180 °C) during ascent. Notice that $h_{\text{lam}} \propto v^{1/2}$, but $h_{\text{turb}} \propto v^{4/5}$, i.e. more heat flux if turbulent, but more pressure loss.

Heat convection in space

- **Inside** pressurized spacecraft (Sputnik, IIS), inside fuel tanks and rockets, inside cooling fluid loops and heat pipes.
- **Outside** spacecraft in planetary atmospheres: ascent, descent, landers, rovers, habitats (and strato-airship and balloon). In orbit, convection outside is negligible in spite of $T_{LEO}=1500\pm 500$ K of the residual gas by UV absorption. Even for stratospheric ships outside convection is negligible, in spite of large surface temperature gradients and wind fluctuations (but convection is dominant during ascent, and descent).
- Difficult handling of liquids under microgravity; where is the free surface if there isn't up and down?
- Lack of natural convection causes larger thermal stratification in cryogenic tanks, which may cause a violent boil-off. It also greatly affects combustion in space.
- At a planet surface, $T_{soil\ max}$ & $T_{soil\ min}$ are outside $T_{air,max}$ & $T_{air,min}$.
- A question related to planet temperature: is there a greenhouse effect on Mars?
 - Yes but $\Delta T_{Mars}=5$ °C ($\Delta T_{Earth}=33$ °C). How is that, if $x_{CO_2,Mars}=95$ % & $x_{CO_2,Earth}=0.04$ % ? 1st: $\Delta T_{Earth,CO_2}=10$ °C.; 2nd: $p_{CO_2,E}=x_{CO_2,E}p=40$ Pa & $p_{CO_2,M}=0.95\cdot 610=580$ Pa, hence a $\times 15$ factor, but...; 3rd: effect of [nearby](#) molecules on broadening absorption lines (i.e. the other molecules make the CO₂ more opaque).
 - On Venus the greenhouse effect is overwhelming, $T_{surf}=735$ K=462 °C, because $p_{CO_2,Earth}=x_{CO_2,Earth}p=0.965\cdot 9.2$ MPa=9 MPa.
 - On Titan the greenhouse effect should be large in spite of its atmosphere being 98.5 % N₂ and 1.5 % CH₄ because $GWP_{CH_4}=33$ (at 100 yr period on Earth); $p_{CO_2,T,eq}=x_{CO_2,E}pGWP=0.015\cdot (147\text{ kPa})\cdot 33=73$ kPa, but it has an opaque atmosphere, with a haze layer 100..200 km above its surface.

Combustion on ground and in space

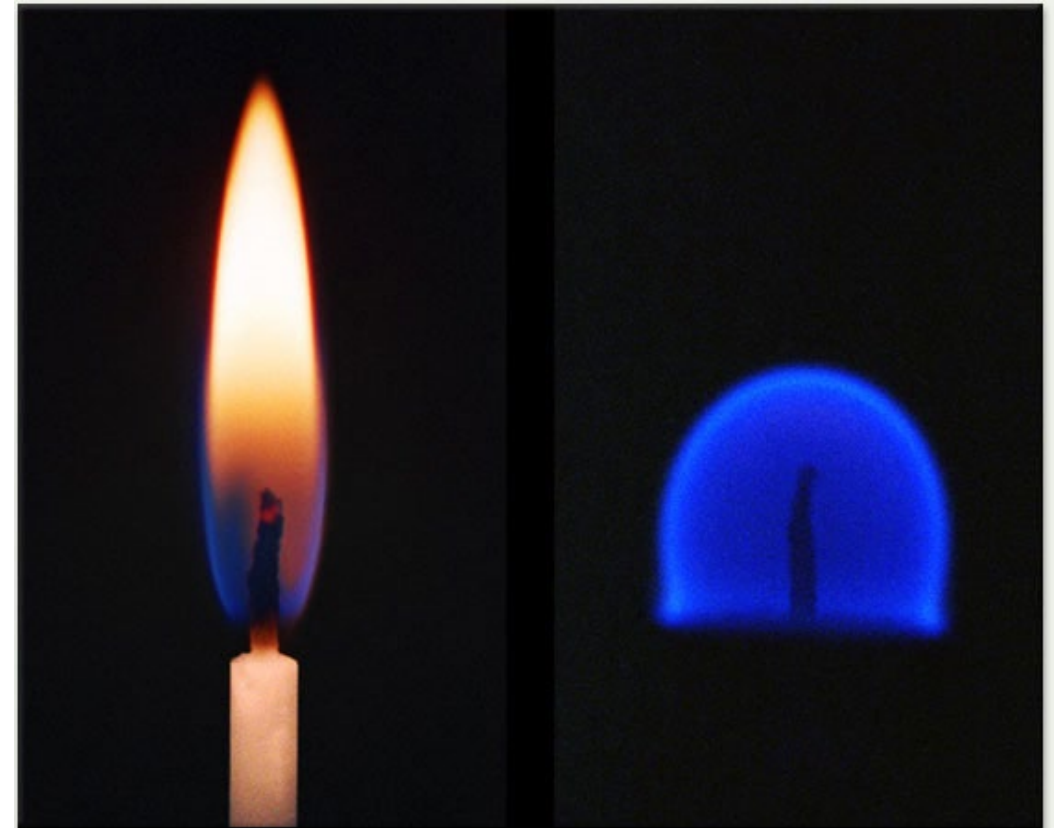
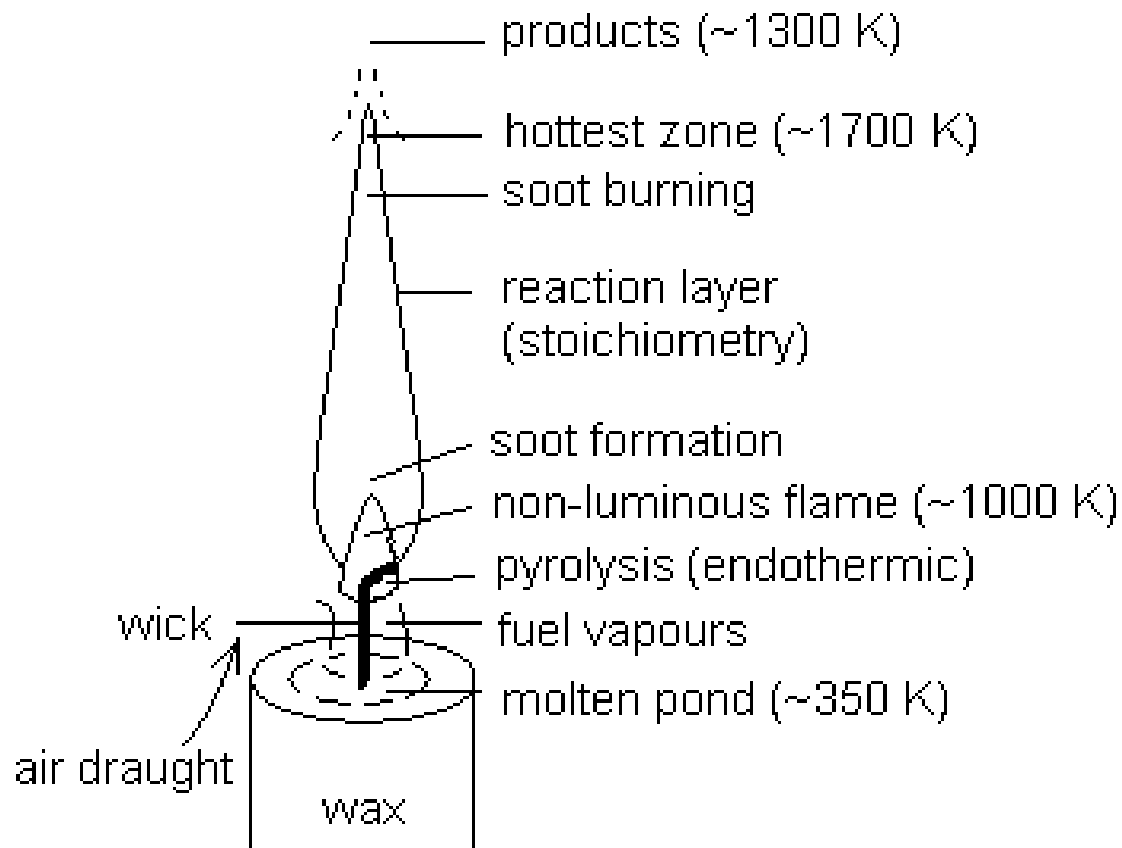

Fig. 3. a) Structure of a candle flame. b) Candle flame on ground and under microgravity ([NASA](#))..

Examples of single-phase fluid cooling

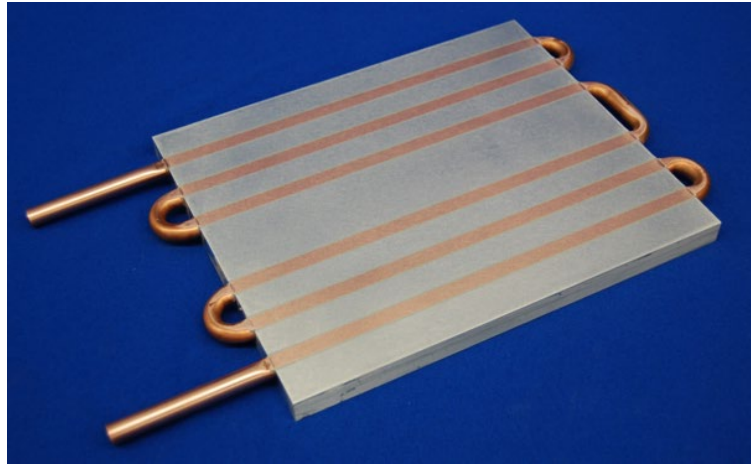

Fig. 4. Liquid-cooled cold plate.

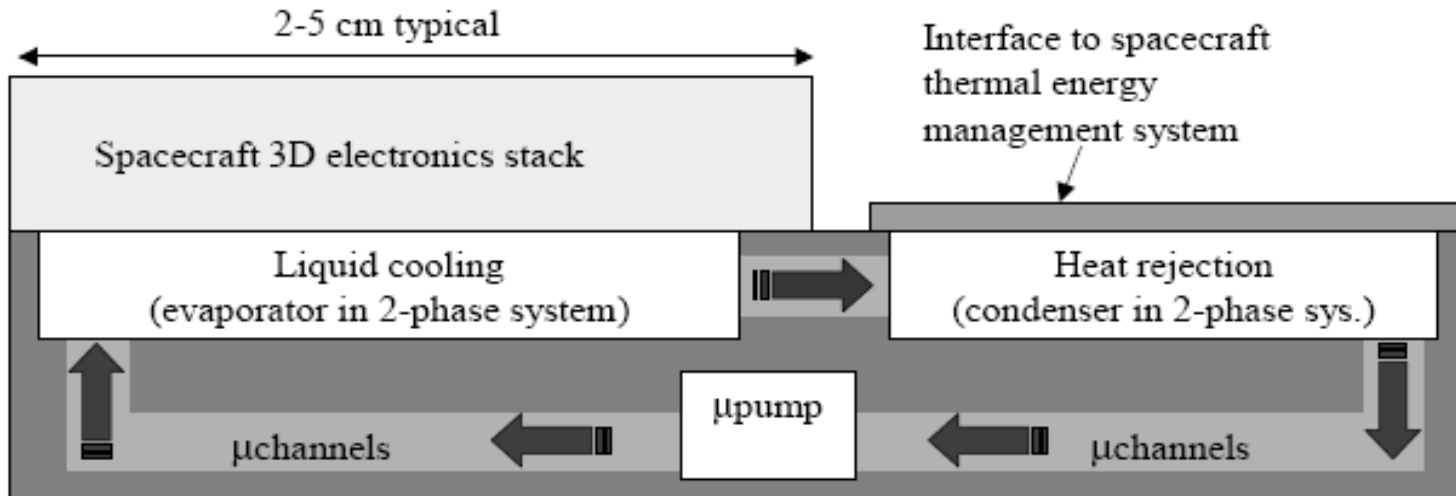

Fig. 5. MEMS-based pumped cooling system.

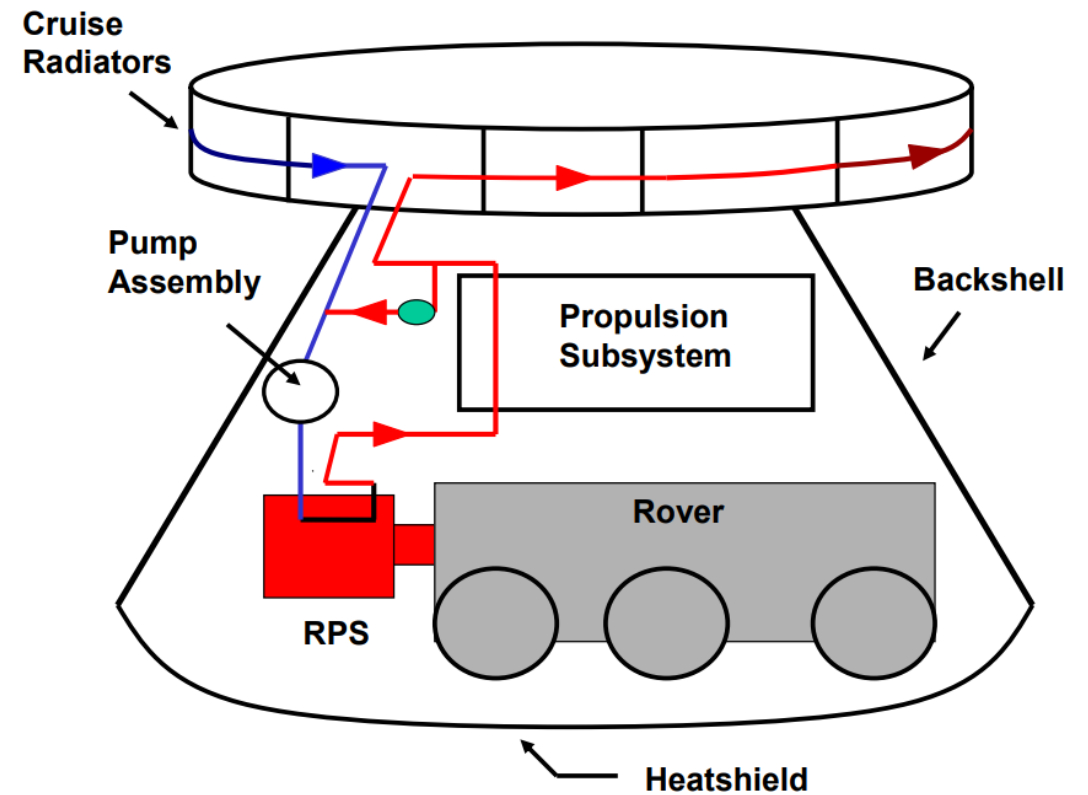

Fig. 6. Heat rejection system of Mars Science Laboratory (MSL) during cruise phase. Single phase Freon 11 picks up heat from the radioisotope power source (RPS) in the [Curiosity](#) rover, and rejects it at the cruise service radiator (4.5 m in diameter).

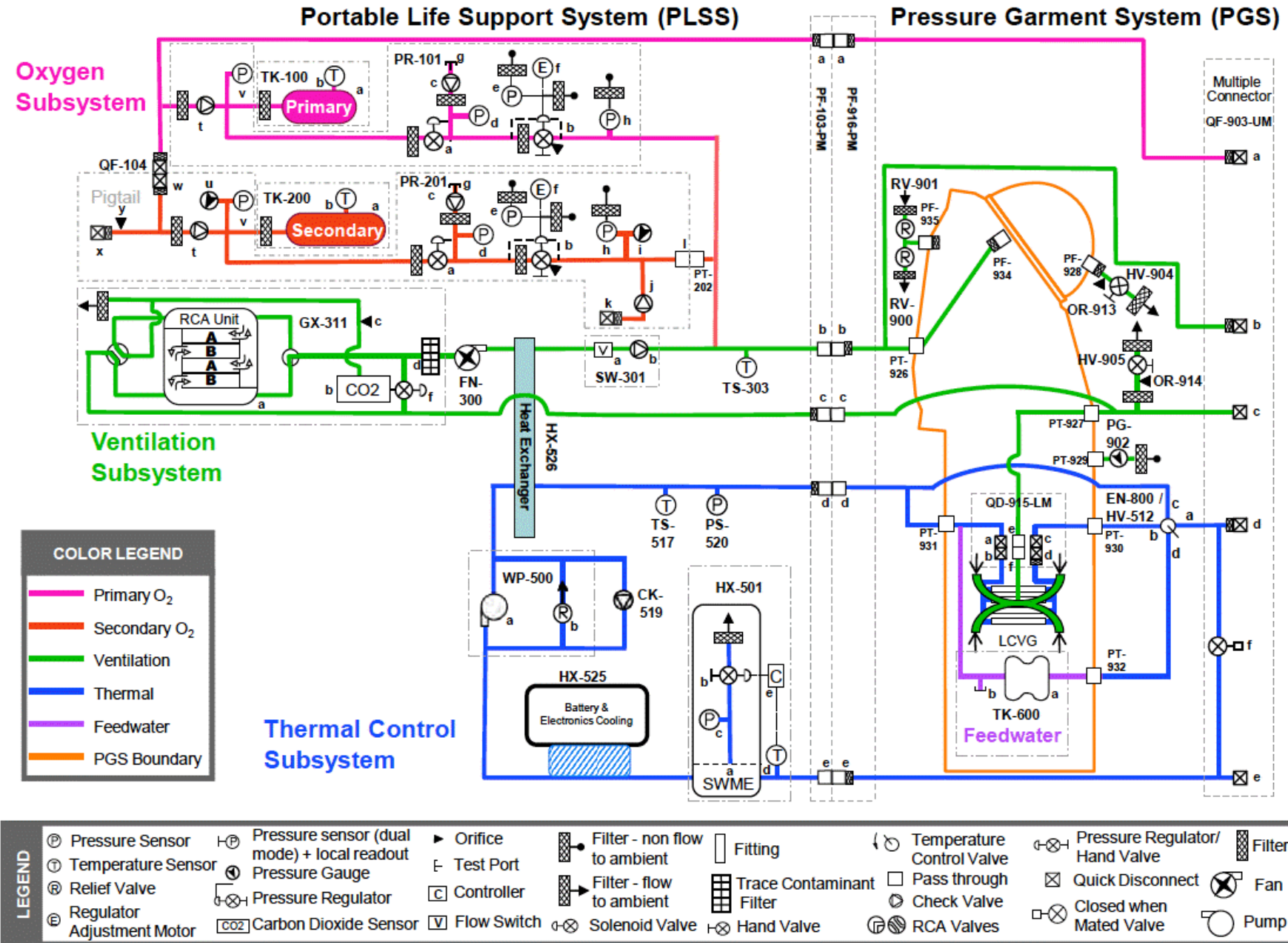

Fig. 7. Scheme of EVA suit, with PLSS backpack and pressure garment.

Classification of heat convection processes

(free / forced, internal / external, laminar / turbulent, single flow / two-phase flow)

Single-phase flow / [Two-phase flow](#)

We only consider liquid/vapour mixtures, not solid/liquid (e.g. phase change materials, PCM, widely used in thermal control too, neither liquid/liquid mixtures like oil and water).

We only consider liquid/vapour mixtures with [phase change](#), either from simple fluids (water, ammonia, freons) or from mixtures (two phase solutions), but not liquid/vapour mixtures without phase change (e.g. air with low-vapour-pressure liquids).

- The large density difference gas/liquid makes gravity dominant.
- The presence of a non-condensable gas decreases the heat-transfer rate, due to the diffusion-resistance it opposes.
- Surface tension and wettability have a strong influence.
- The sound speed changes dramatically (easily yielding a choked flow in orifices).
- Heat convection strongly depends on flow structure.
- Effect of gravity on boiling and condensation (in pure substances, and in mixtures like humid air).
- Numerical simulation usually based on [VOF](#) modelling.
- Phase diagram & [metastable states](#).

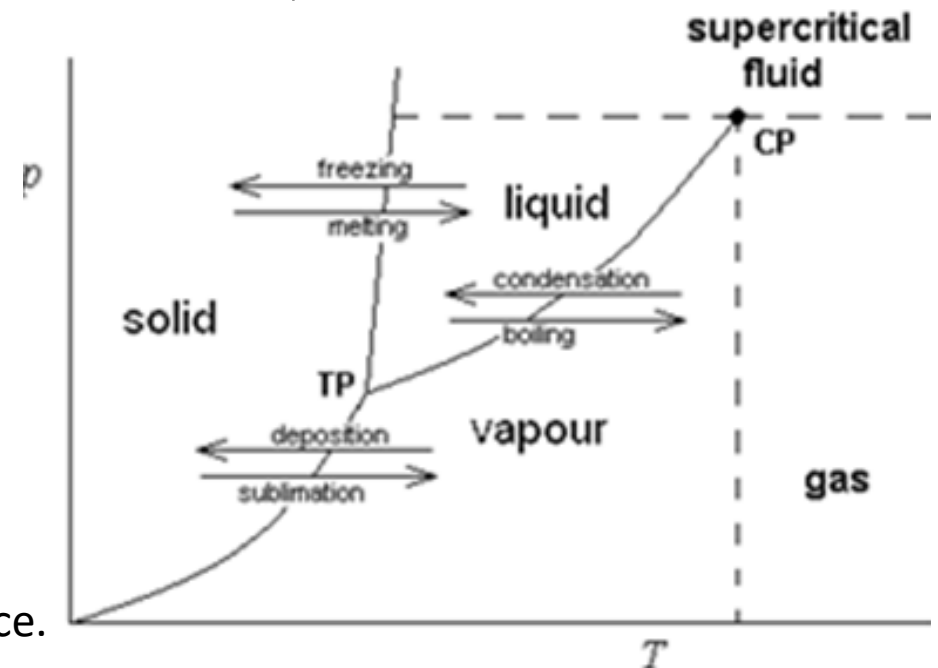

Fig. 8. Phase changes in a pure substance.

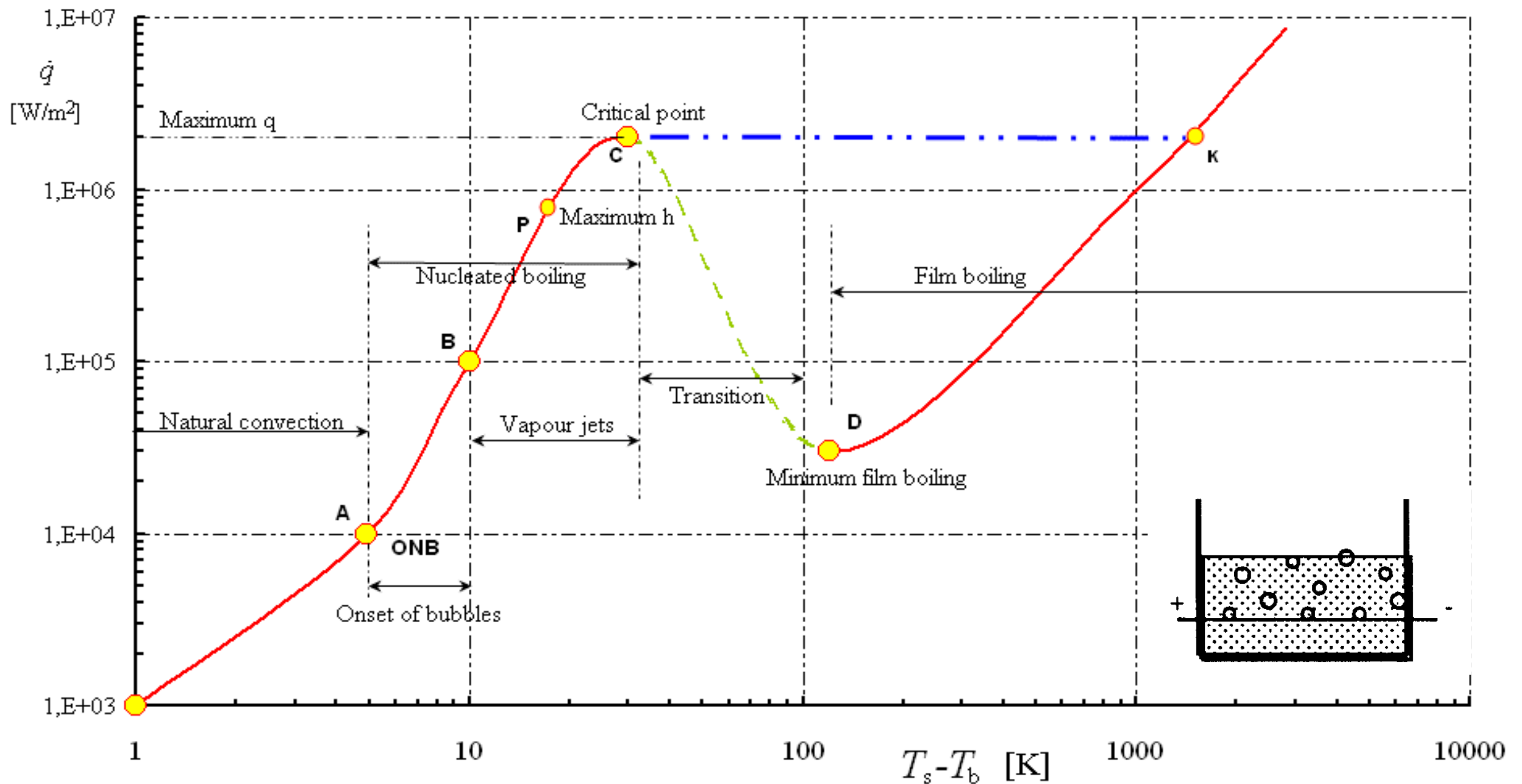

Fig. 9. Pool boiling regimes (values applicable to boiling water at normal pressure in air, by a heated horizontal wire; $T_b=100$ °C).

Heat convection in two-phase-flow circuits

- Active vs. passive (i.e. requiring external power or not).
- Best to pump the liquid than to compress the vapour (would need more power). Pumps are electrically powered. In some cases, liquid jets (spray cooling) and ejectors are used. Expandable evaporative cooling systems (flash cooling) are not considered here, but later.
- The liquid vaporizes when heat is absorbed from the source, and condenses when heat is released to the sink (a heat exchanger or the final radiator).
- Non-flammable low-boiling-point fluids are used: ammonia, freons, CO₂...
- Active, pump-assisted two-phase-flow cooling systems are more powerful than passive systems; they can transmit more thermal power and at greater distances, and more versatile (they can easily accept and reject heat at multiple locations), but they are more complex than solid conductors (the best for short distances), and single-flow or passive two-phase flow loops. They are a source of vibrations, and may leak.

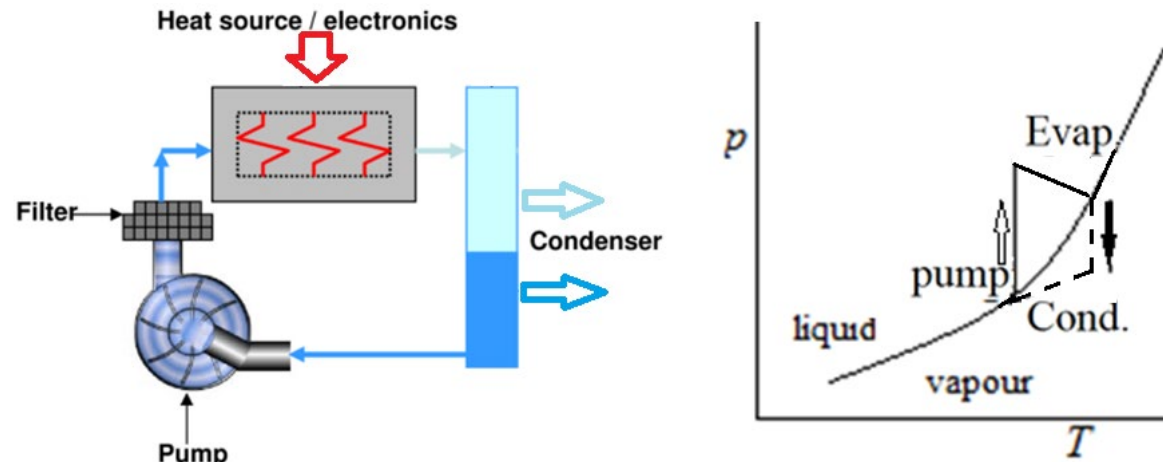

Fig. 10. Schematic of a two-phase fluid cooling loop and its process diagram.

Passive heat convection in two-phase-flow systems

- Passive pumping may be by buoyancy (thermosiphon), or by capillarity (heat pipes and vapour chambers), or by asymmetric flow of liquid slugs between vapour plugs ([pulsating heat pipes](#)).
- Most are longitudinal (heat pipes), but some are 2D (vapour chambers).

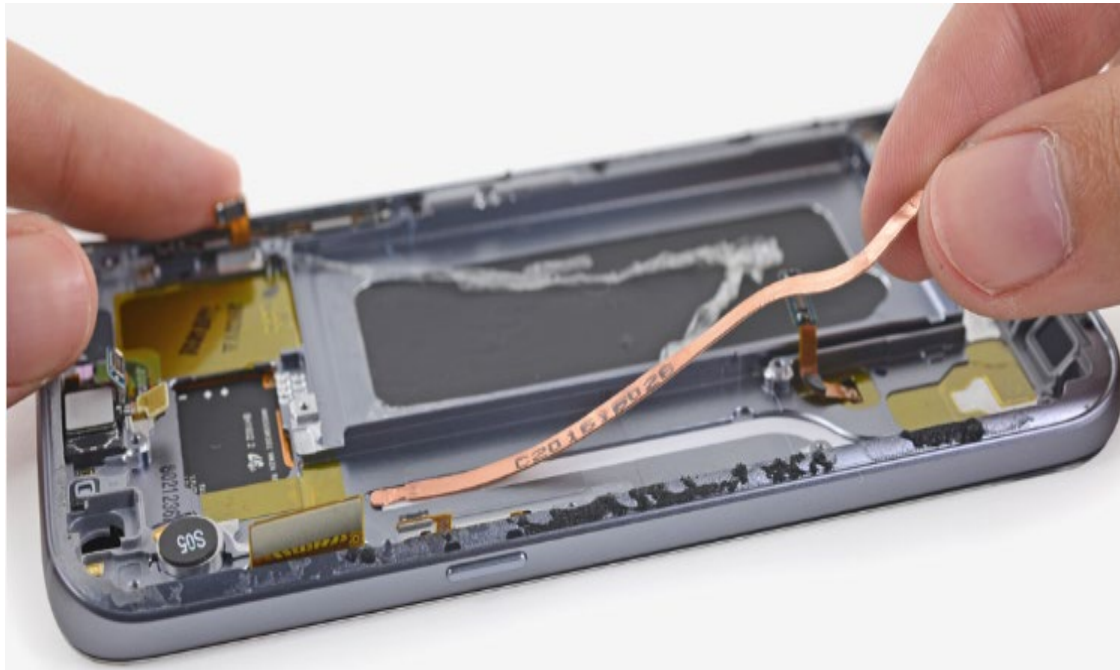

Fig. 11. **Heat pipe** 0.4 mm thick inside Samsung [S7](#) smartphone.

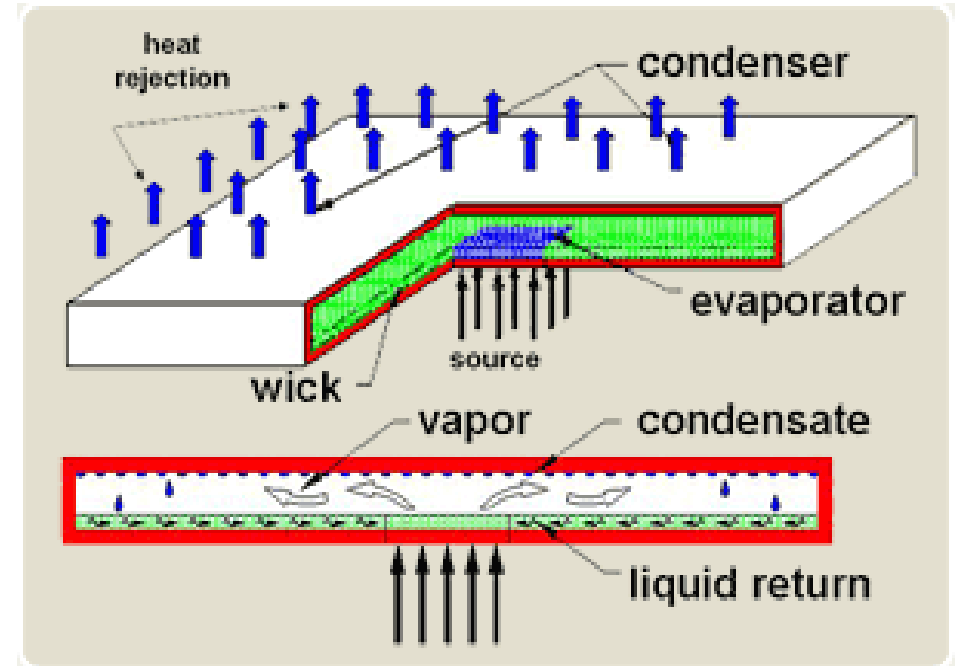

Fig. 12. **Vapour chamber** [heat spreader](#).

Heat pipes

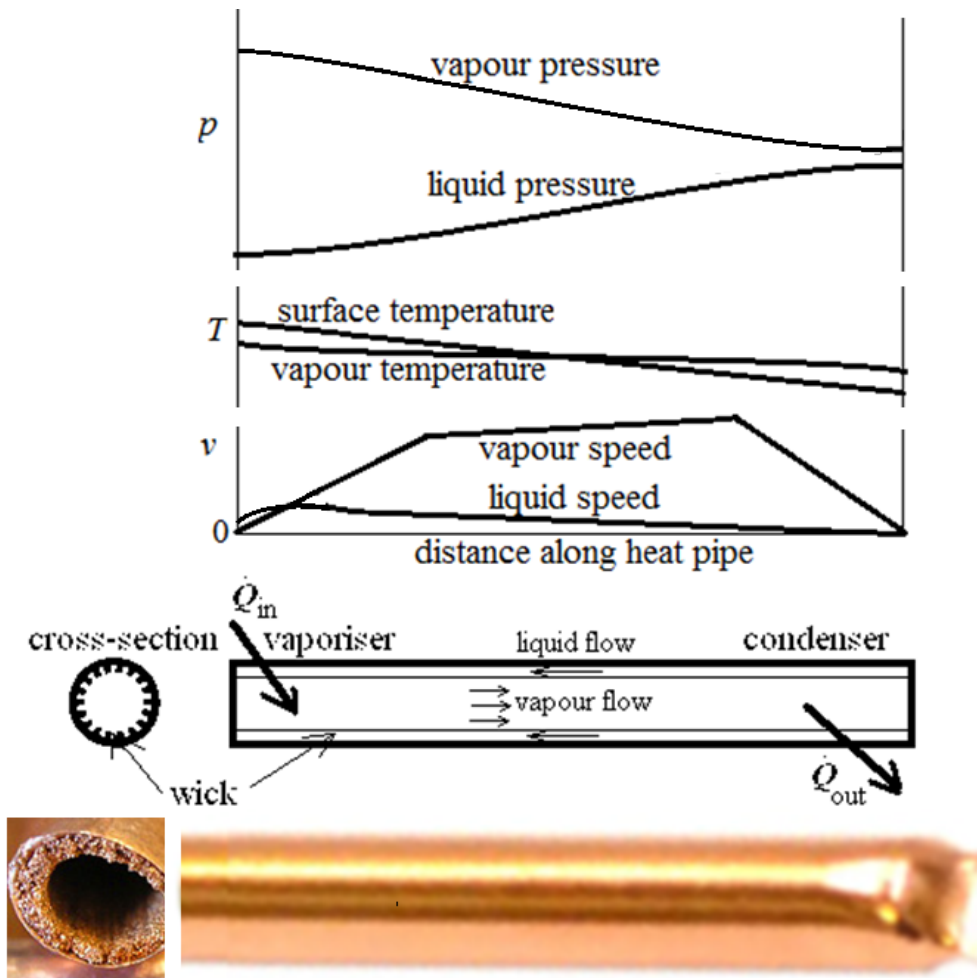

Fig. 13. Cut of a stick heat pipe (SHP) with sketches for heat and fluid flows, and velocity, temperature and pressure profiles during operation.

- Working fluid (two-phase), envelop, and wick (the capillary device, which may be sintered powder, wire mesh, grooves, or tiny tubes); common fluid-wick-wall triplets are $H_2O-Cu-Cu$ and $NH_3-Ni-SS$.
- Must operate far from the freezing and critical temperature limits.
- Total pressure drop balanced by capillary pressure $\Delta p_C = 2\sigma \cos\theta / r_{pore}$.
- Gravity direction crucial: level, favourable, adverse.
- Liquid pressure loss $\propto 1/r_p^2$ but capillary pressure $\propto 1/r_p$ means there is an optimum r_p .
- If evaporator power is raised a lot, dry-out may occur, with a jump in T_e .
- Effective conductivity may approach 10^5 W/(m·K); compare with $k_{Cu} = 390$ W/(m·K); e.g. a $D = 4$ mm $^\phi$, $L_{eff} = 100$ mm, water-in-copper heat pipe used for CPU cooling, may evacuate 50 W with just $T_e - T_c = 1$ °C. $L_{eff} = L_e/2 + L_a + L_c/2$
- High velocity vapour flow at low temperature (low density), may strip counter-flowing liquid out of the wick.

Loop heat pipes (LHP)

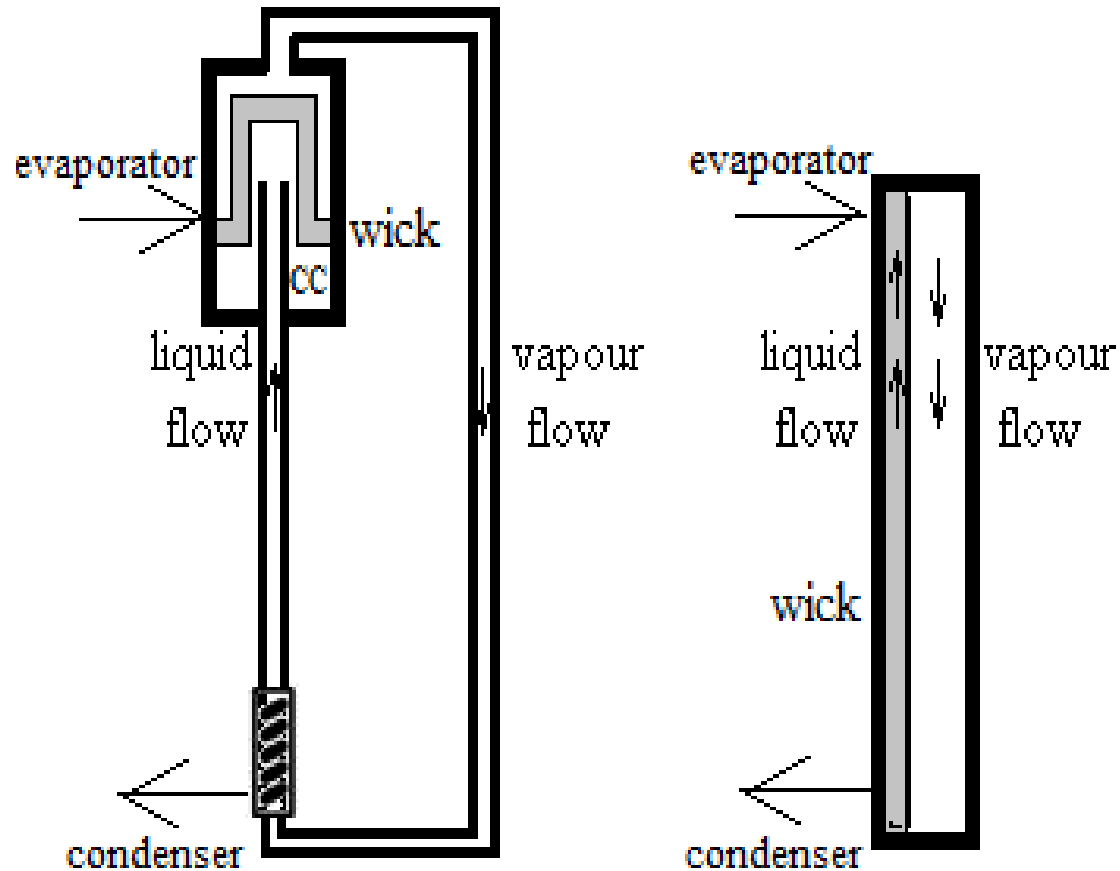

Fig. 14. Sketch of a loop heat pipe (LHP), and comparison with a stick heat pipe (SHP) in a planar 2D sketch, depicted as in a vertical position against the gravity field (adverse layout).

- Vapor and liquid flow in the same direction instead of countercurrent flows.
- Smooth tubes of $d=3..7$ mm are used for the rest of the loop, and can be separately sized to reduce pressure drops. $D_{\text{evaporator}}=10..30$ mm.
- Wick only in the evaporator (wick pores can be smaller, e.g. sintered powders and metallic foams). A fine-pore primary wick ($d_p=1..5$ μm) provides the pumping, and a coarse wick feeds liquid from the compensation chamber.
- The compensation chamber (CC) is a fluid reservoir integral to the evaporator (applying heat or cold here may control LHP performance).
- A LHP could be shut off if (e.g. during eclipse) by adding a pressure-regulating valve in the loop, or by placing an electrical heater in the liquid line or on the CC (but this requires power).

Loop heat pipe (LHP) thermodynamics

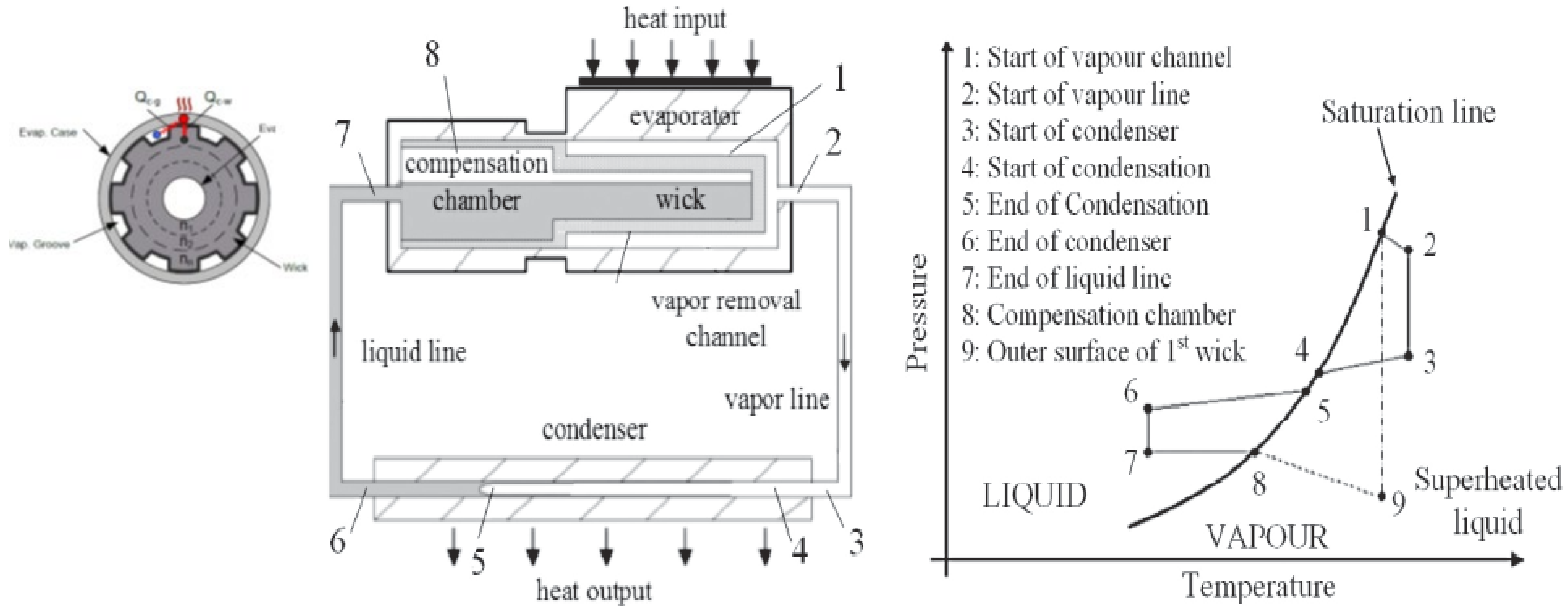

Fig. 15. LHP fundamentals.

Expendable two-phase cooling systems

Evaporation from a liquid or sublimating solid absorbs enthalpy, producing a cooling effect (as well as other endothermic processes like mixing a salt in water and ice).

- Most cryogenic tanks (LHe, LH₂, LN₂, LOX, LNG...) use evaporative cooling, and the boil-off venting is used to absorb outside heat input, hence avoiding the need of cryocoolers.
- Evaporative cooling under vacuum can provide powerful cooling with little exposed area; that is why it is used in EVA suits and most other crewed spacecraft (from Mercury program to Space Shuttle).
- The expendable water and porous plate are cooled by the vaporisation effect, and then the base plate and a secondary fluid circuit are cooled by heat conduction from the chilled water.
- Notice that evaporative cooling is a refrigeration process, not just a heat transfer process, i.e. temperature can be lowered below that of the environment (as seen in the next example). Most refrigerators and heat pumps (except thermoelectric devices) make use of a working fluid to pump heat up over the ambient temperature, and the same is valid for most heat engines; convection is a common process in most thermodynamic applications.

Example of evaporative cooling

Question. To keep a Venus lander at $<60\text{ }^{\circ}\text{C}$ in a $460\text{ }^{\circ}\text{C}$ environment for a period of 100 h, with equipment dissipating 100 W, an ammonia tank is to be used for evaporative cooling. As NH_3 has low vapour pressure at that temperature, helium from another tank is injected to keep pressure at 10 MPa inside the NH_3 tank, which vents to a 9.2 MPa atmosphere. Find the amount of NH_3 and He required.

Answer. Let start assuming that the heat input from the environment is negligible in comparison with the internal dissipation (e.g. by using a good MLI envelop), and that boiling is the main cooling effect. At $60\text{ }^{\circ}\text{C}$ $h_{\text{LV,NH}_3}=1.0\text{ MJ/kg}$, so that a first guess for the 100 h is $m=Qt/h_{\text{LV}}=100\cdot 100\cdot 3600/10^6=36\text{ kg}$ of NH_3 . But at $60\text{ }^{\circ}\text{C}$ $p_{\text{LVE,NH}_3}=2.6\text{ MPa}$, so that the other $10-2.6=7.4\text{ MPa}$ must be provided by He gas; i.e. for every 2.6 mol of NH_3 (44 g), 7.4 mol of He (29.6 g), and, as 36 kg NH_3 are vented, $36\cdot 29.6/44=24\text{ kg}$ of He will be entrained. Notice how important it is for the boiling fluid to have a large vapour pressure, what makes NH_3 ideal; e.g. if we could operate at $80\text{ }^{\circ}\text{C}$, $p_{\text{LVE,NH}_3}=4.1\text{ MPa}$ and $h_{\text{LV,NH}_3}=0.87\text{ MJ/kg}$, hence $100\cdot 100\cdot 3.6/870=41\text{ kg}$ of NH_3 and $41\cdot(5.9\cdot 4)/(4.1\cdot 17)=14\text{ kg}$ of He, i.e. 55 kg in total (against 60 kg at $60\text{ }^{\circ}\text{C}$).

Notice that, although we have only accounted for the internal heat dissipation, it would be easy to cope with the external heat input from the $460\text{ }^{\circ}\text{C}$ environment, by providing a heat exchanger surrounding the lander, in which the cold gas exhaust at $60\text{ }^{\circ}\text{C}$ will absorb the incoming heat. In the ideal case, the exhaust gas will absorb heat from $60\text{ }^{\circ}\text{C}$ to $460\text{ }^{\circ}\text{C}$. With molar fractions $x_{\text{NH}_3}=0.26$ & $x_{\text{He}}=0.74$ (mass fractions $y_{\text{NH}_3}=0.60$ & $y_{\text{He}}=0.40$), and averaged $c_{p,\text{NH}_3}=3\text{ kJ}/(\text{kg}\cdot\text{K})$ & $c_{p,\text{He}}=5\text{ kJ}/(\text{kg}\cdot\text{K})$, the venting gas would absorb $\Sigma mc_p\Delta T=(36\cdot 3+24\cdot 5)\cdot(460-60)=91\text{ MJ}$ in the 100 h period, i.e. about 250 W. The record stage at Venus is 2 h ([Venera-13](#)).

Sublimator

- It is based on a layer of water between a warm plate and a porous plate under vacuum ($p_{\text{ext}} < p_{\text{tr}} = 0.6 \text{ kPa}$, hence not good for Mars), with the formation of an ice front layer. Porosity, $\phi \sim 0.3$, and porous size, $d_{\text{pore}} \sim 5 \mu\text{m}$, and plate thickness, $\sim 1 \text{ mm}$ sintered stainless steel, are optimised to provide an adequate pressure drop on the gas flow.. Increasing heat load raises water temperature, moving the evaporation front outwards until blow-off (maximum load). On the contrary, decreasing heat load too much will freeze all the water layer (the container may burst).
- Requires to expend water at a rate inversely proportional to vaporization enthalpy, i.e. $1/h_{\text{LV}} = (1/2.5) \text{ kg/MJ} = (3.6/2.5) \text{ kg/kWh} = 1.5 \text{ (kg/h)/kW}$. But it is very light and compact ($m \sim 1 \text{ kg}$, $V \sim 5 \text{ L}$). Sublimators are used in all extravehicular space suits (EMU), on Apollo lunar Module (ALM), other short-duration high-cooling applications, and for sporadic peak loads in long missions.

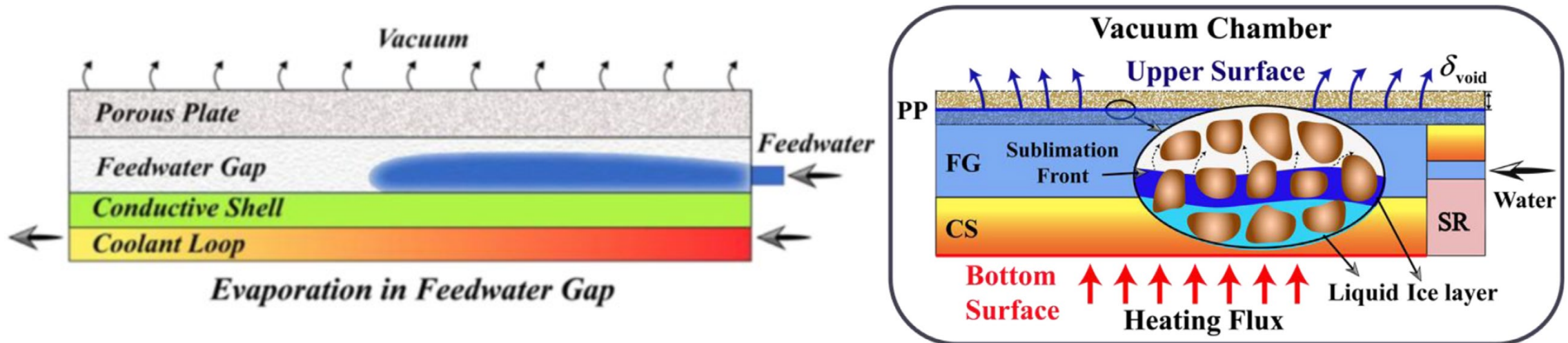

Fig. 16. Illustrations of a sublimator ([2020-Zhang et al.](#)).

Sublimator (T-profile)

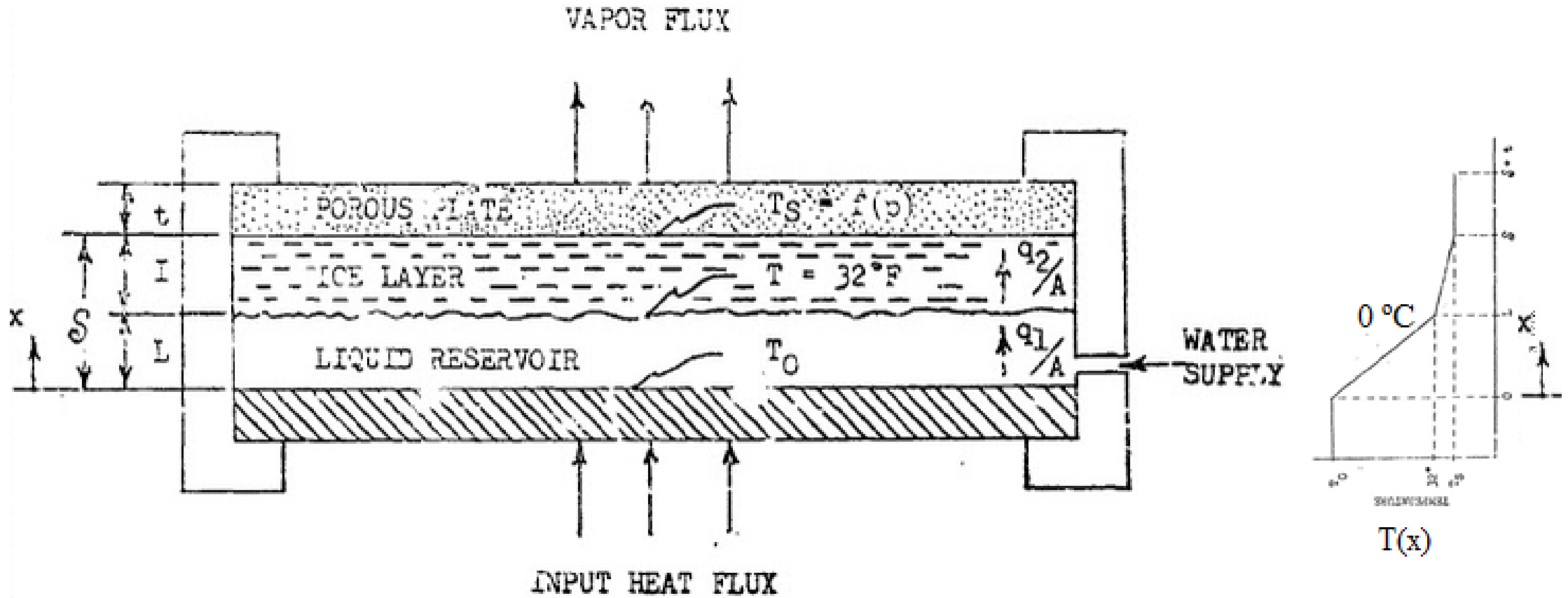

Fig. 17. Scheme of an EVA space-suit sublimator, and 1D temperature profile.

Heat exchangers (HX, or HE)

Devices to exchange thermal energy between two or more fluids (for heating or cooling)., usually through solid walls. Types:

- According to fluid phase: single-phase flow (liquid/liquid, liquid/gas, gas/liquid, gas/gas), or two-phase flow (evaporators & condensers).
- According to flow direction: counterflow, coflow, mix flow, single pass, multiple pass.

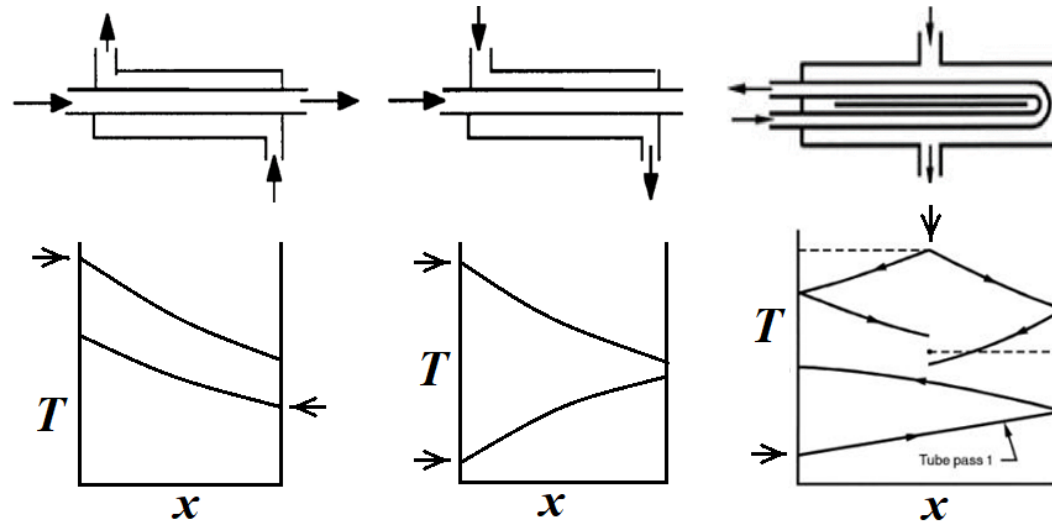

Fig. 18. Types of flow direction in heat exchangers.

- Energy balance without phase change, all HX types; f is a type-factor relative to counterflow type:

$$\dot{Q} = (\dot{m}c_p \Delta T)_{\text{cold}} = (-\dot{m}c_p \Delta T)_{\text{hot}} = fKA\Delta T_{\text{LMTD}} = fKA \frac{\Delta T_{\text{left}} - \Delta T_{\text{right}}}{\ln(\Delta T_{\text{left}} / \Delta T_{\text{right}})}$$

- According to HX morphology: shell-and-tube, STHX; plate, PHX; open-flow, OFHX; contact HX (recuperators, regenerators, cooling towers).

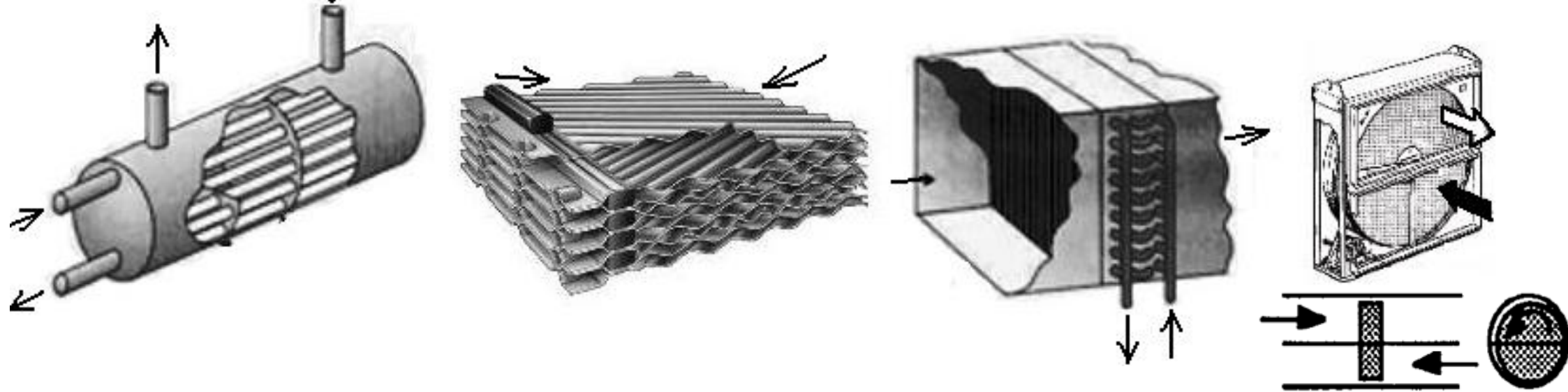

Fig. 19. Different types of heat exchangers: a) STHE, b) PHE, c) OFHE, d) Regenerator wheel.

- According to maintenance: dismountable and reconfigurable (with gaskets), or brazed (can be cleaned passing a special fluid through, e.g. [video](#)).
- According to compactness:
 - Normal, if hydraulic diameter of cross-section, $D_h = 4 \cdot \text{Area} / \text{Perimeter} > 5 \text{ mm}$. Heat transfer area density, $\beta < 500 \text{ m}^2/\text{m}^3$.
 - Compact heat exchangers, if $1 < D_h [\text{mm}] < 5$, or $400 < \beta [\text{m}^2/\text{m}^3] < 3000$.
 - Micro heat exchangers if $D_h < 1 \text{ mm}$ (or $\beta > 3000 \text{ m}^2/\text{m}^3$). Printed circuit HX. Human lung alveoli are typically 0.2 mm in size and have some 15 000 m^2/m^3 . For $D_h > 0.2 \text{ mm}$, conventional correlations apply.

Thermal Protection Systems (TPS)

- We focus on TPS for spacecraft descent ([EDL](#)) in planetary atmospheres, where vehicle deceleration by air-drag creates $T_{\text{bow}} > 8000$ K at the shockwave, while spacecraft structure must be maintained at $T_{\text{Al,work}} < 450$ K. But reentry burning is good for spacecraft final demise.
- Ascent is much milder, $T_{\text{max}} < 200$ °C because it is propulsive. At $z=100$ km ([KL](#)), $\rho=10^{-6}$ kg/m³, ascent is at $M=8$, and descent at $M=25$.

But cryogenics need insulation; e.g. Shuttle external tank $D=8.4$ m, $L=47$ m (17 m top LOX at 90 K, 30 m bottom LH2 at 20 K, $d_{\text{Al}}=12$ mm, $d_{\text{PUfoam}}=25$ mm, $\rho=40$ kg/m³, $k=0.02$ W/(m·K); 0.007 in vacuum. In-site sprayed polyurethane foam. If $h_{\text{int}}=50$ W/(m²·K) and $h_{\text{ext}}=5$ W/(m²·K), $q=180$ W/m², $Q_{\text{LH2}}=150$ kW \rightarrow $m_{\text{LH2}}=0.3$ kg/s (1 t/h). Filled 3 h before. LH2/LOX lasts for 9 min (solid boosters only for 2 min). The LOX tank is on top to have an advanced centre of mass for aerodynamic stability.

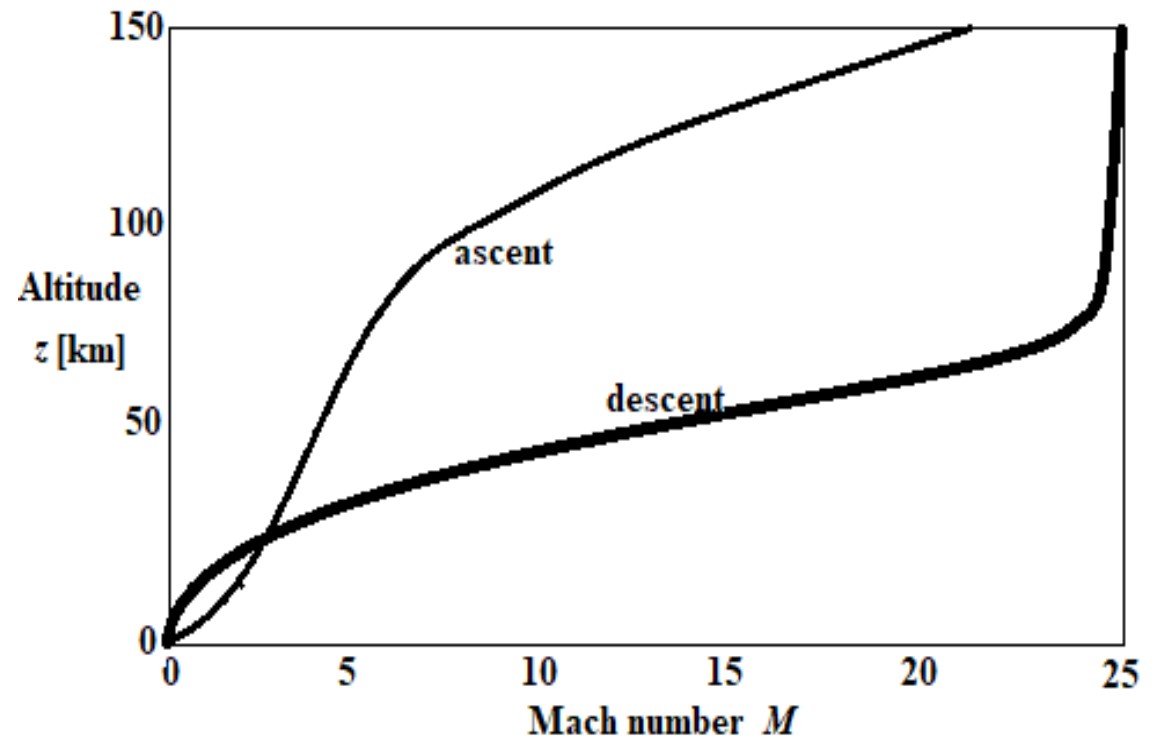

Fig. 20. Ascent vs. descent trajectory.

Thermal Protection Systems (TPS)

- Reentry requires an ablator shield, though for $v < 7.5$ km/s, the heat flux is $q < 1$ MW/m² and reusable refractories may work without mass loss (by re-radiation).
- In an ablator, incoming heat flux is absorbed by endothermic physical & chemical reactions (reactive flows), and expelled outwards with the product gas (from pyrolysis of polymeric porous composite material), cooling the char.
 - $T_{\text{bow shock}} \approx 8000$ K, $x = -0.2$ m, $\text{O}_2 = 2\text{O}$, $\text{N}_2 + \text{O}_2 = 2\text{NO}$, $\text{N} = \text{N}^+ + \text{e}^- \dots$
 - $T_{\text{boundary layer edge}} \approx 6000$ K, atoms, ions and electrons
 - $T_{\text{char,out}} \approx 3000$ K, ablat. $\text{C}(\text{s}) + \text{O}(\text{g, income}) = \text{CO}(\text{g})$
 - $T_{\text{char,in}} \approx 1200$ K, coking: $\text{C}_6\text{H}_2(\text{g}) = 6\text{C}(\text{s}) + \text{H}_2(\text{g})$
 - $T_{\text{virgin,in}} \approx 450$ K, pyrolysis: $\text{C}_6\text{H}_6\text{O}(\text{s}) = \text{C}_6\text{H}_2(\text{g}) + \text{H}_2(\text{g}) + \text{H}_2\text{O}(\text{g})$
 - $T_{\text{Al,shell}} \approx 300$ K.

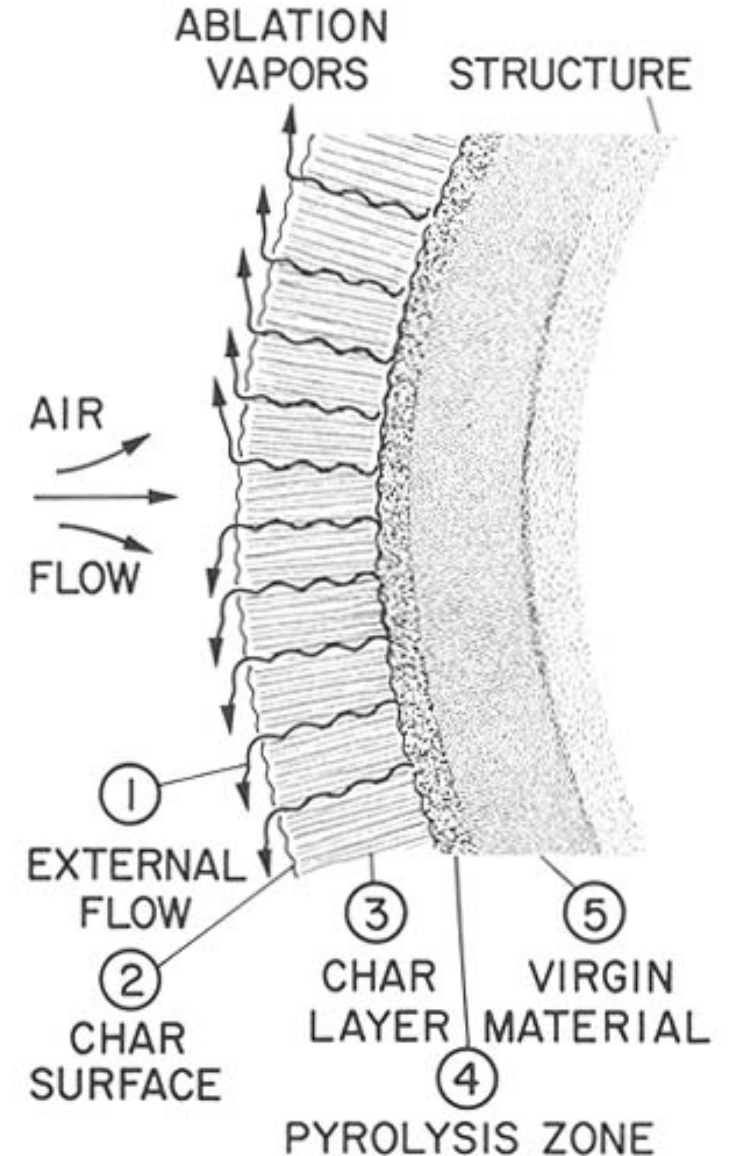

Fig. 21. Ablation shield pyrolysis.

Bow shock

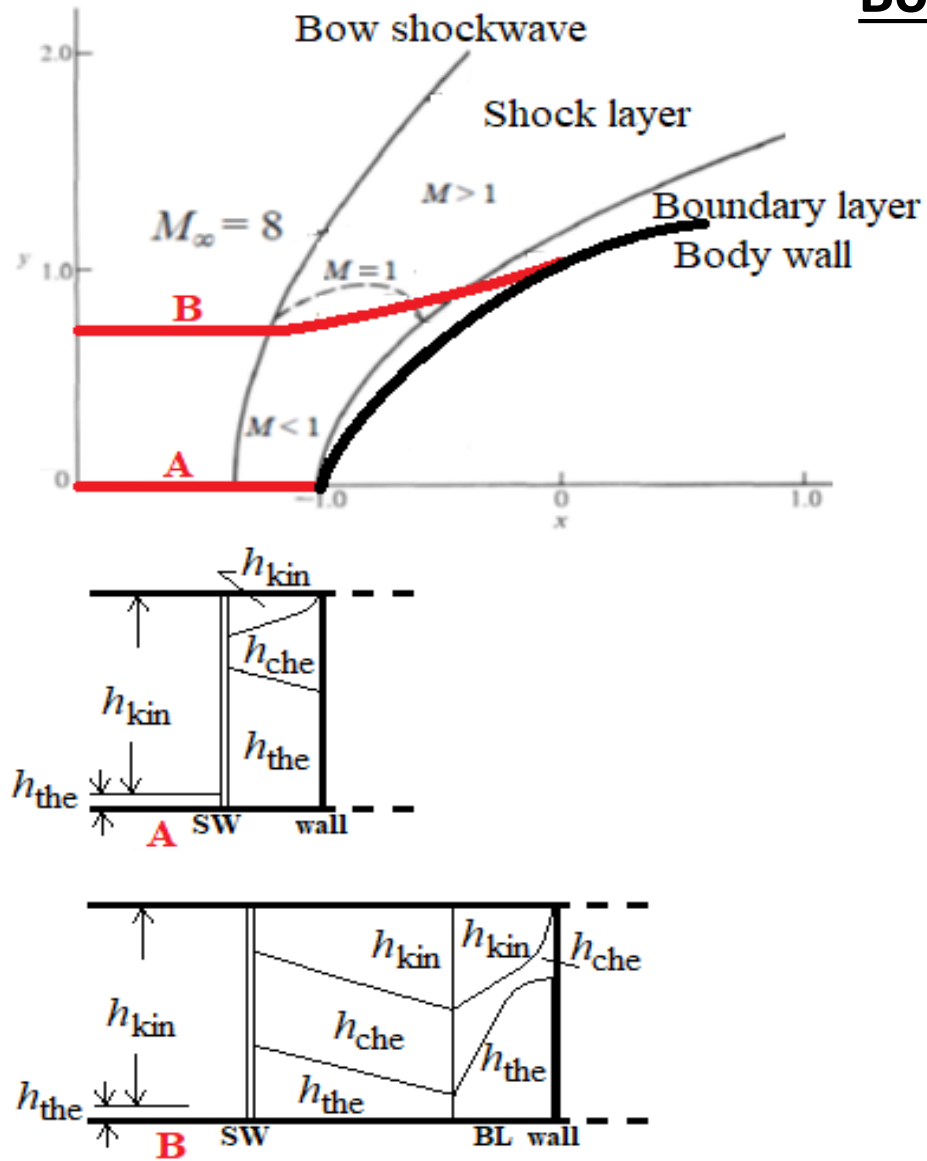

Fig. 22. Flow structure and enthalpy distribution.

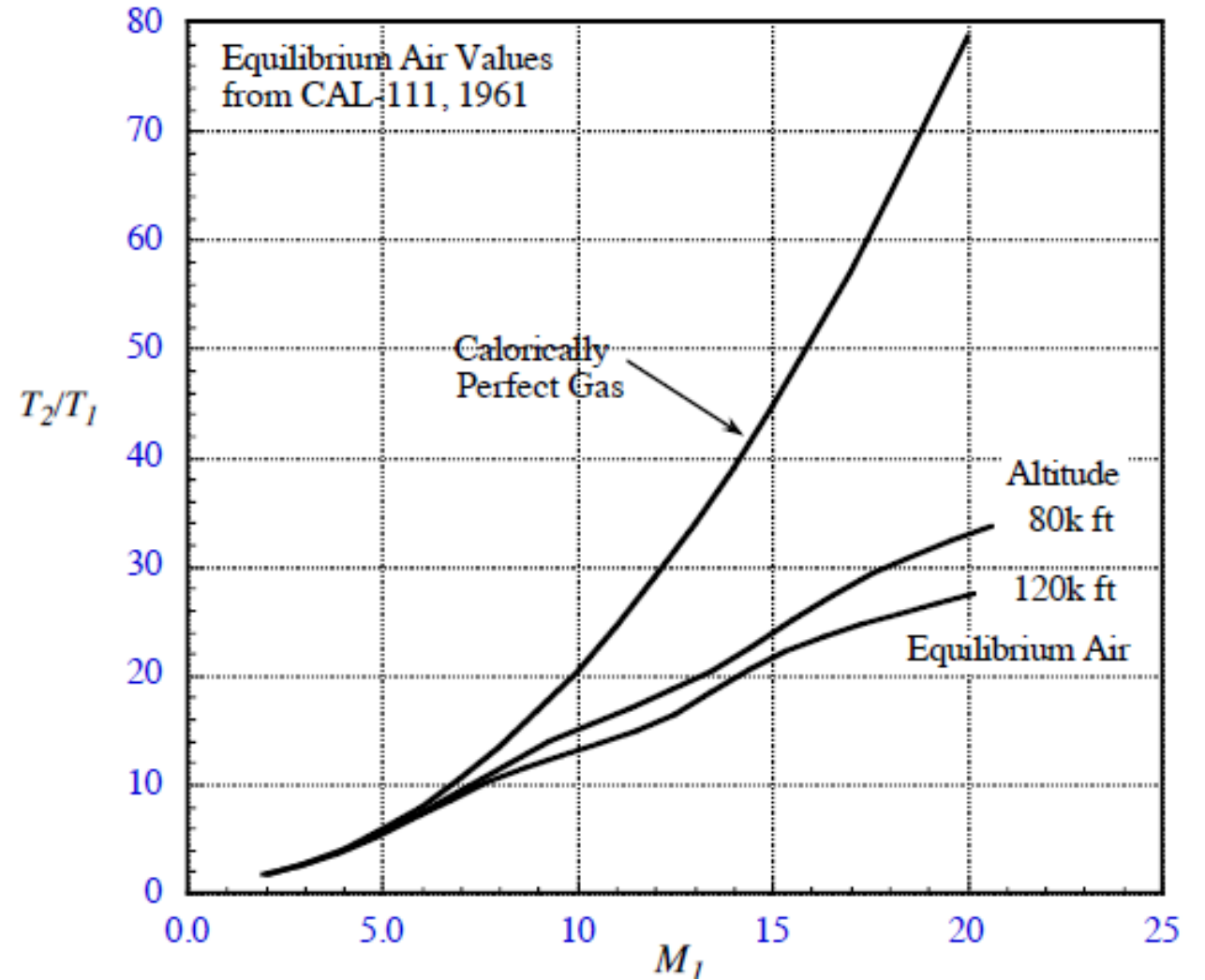

Fig. 23. Temperature jump at a normal shockwave vs. incident Mach.

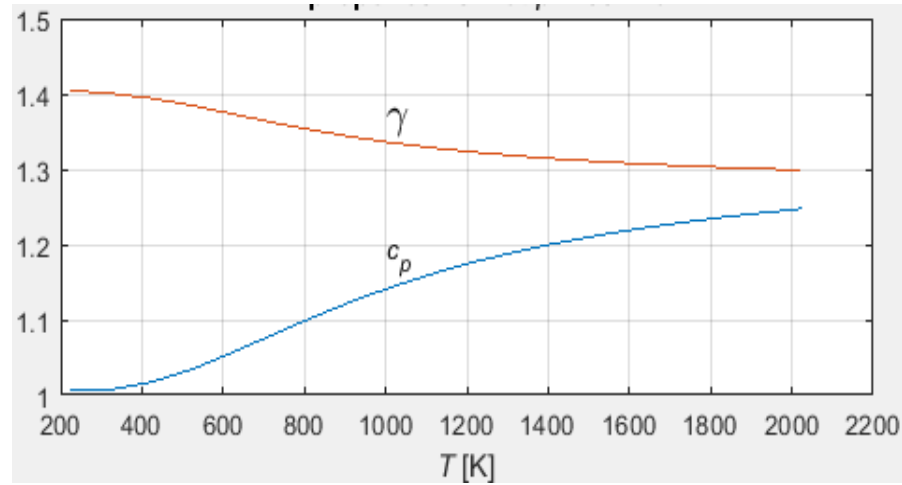

Fig. 24. Variation of c_p and γ for air at low pressure (<100 kPa).

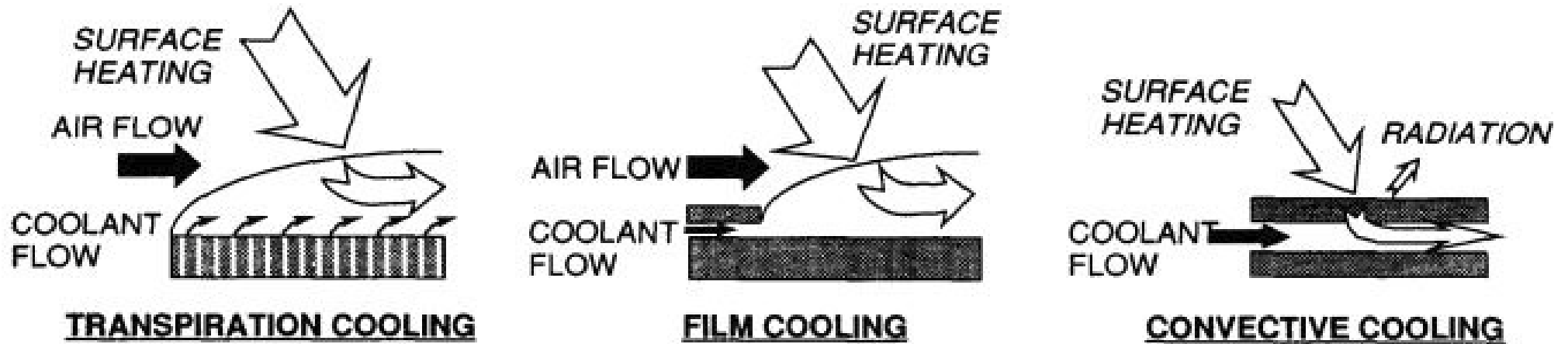

Fig. 25. Active cooling TPS (spendable and recyclable).

Heat convection in space. Summary

- As on ground, thermal convection associated to fluid flow is the most powerful, quicker response, and most versatile means of heat transfer (e.g. it is difficult to imagine a thermal control on the Moon without convection, as for a reversible heat pump; but not impossible: a thermoelectric device might do the work without fluids).
- From simpler to more cumbersome solutions, we have: free or forced clean gas flows, simple liquid circuits, two-phase loops (externally pumped or within heat pipes), and open circuits (expendable fluids, including reactive flows as in ablative TPS). Contrary to solid conduction and radiation, most convection equipment make a noise, from the soft hissing of pipe flow, to the loud operation of valves and motors. Besides, convection is prone to leakage (i.e. contained fluids may escape from tanks and pipes, making a mess in space; beware of pipe freezing).
- Usually, heat is acquired at the source by heat conduction through the source's envelope, it is carried away by fluid flow (often in a cascade of circuits with different fluids and heat exchangers in between), and rejected to background space by radiation (in space; on ground also by convection); additional heat rejection may be provided by expendable evaporative cooling (as in human perspiration and sweating; recall that humans and other living beings need ventilation, that in space must be forced).
- Heat convection during entry into planetary atmospheres is the most demanding thermal problem in spacecraft design.
- Coarse analysis of heat convection is based on empirical correlations at the fluid walls, $Nu=f(Re,Pr...)$, and Newton's cooling law:
$$\dot{Q} = hA(T_{\text{wall}} - T_{\text{fluid,bulk}})$$
- Finer analysis is based on heat conduction within the fluid (energy equation) and [CFD](#) simulation.

Back to [Heat Transfer](#) and [Space Thermal Control](#).